

## Quality of Service Estimation of Multimedia Transmission Using Nonlinear Autoregressive Exogenous Model

Yazeed A. Al-Sbou

Department of Computer Engineering, Mu'tah University, Al-Karak, Jordan  
e-mail: yazeed1974@gmail.com

*Received: December 17, 2016*

*Accepted: February 11, 2017*

**Abstract**— Due to the advances of network technologies and multimedia communications, Quality of Service (QoS) becomes an increasingly important issue in network communications. Many traditional assessment techniques were designed to evaluate the QoS of multimedia applications transmitted over these networks. In this paper, a new QoS evaluation system has been developed. The proposed system is based on using the nonlinear autoregressive with exogenous input model (NARX). This model is preferred because it could reflect the dynamic characteristics of the QoS and network performance. In addition to the QoS parameters, previous QoS values were used as inputs to the developed NARX model. The output is the estimated QoS based on the given inputs. The proposed model was optimized, validated and evaluated based on specified criteria. Simulation results showed that the adopted model presented high accurate QoS prediction capabilities, where the forecasted QoS was very close to the actual QoS values in most of the time period. QoS, in a way, reflects performance resources availability of a network using the devised approach. The estimated QoS can be used to optimize and manage the utilization of network available resources and provide solutions for QoS provision, routing, monitoring, ...etc.

**Keywords**— Exogenous inputs (NARX), Multimedia, Networks, Nonlinear autoregressive network, Prediction, QoS.

### I. INTRODUCTION

Due to the rapid growth of networking technologies and increase of different types of network traffic and applications, Quality of Service (QoS) monitoring, measurement and support for these applications becomes more important. In addition, the huge use and transmission of real-time multimedia applications over communication networks make the problem of supporting and providing reliable services more complicated. A key challenge is how to measure or infer the QoS of these applications accurately for monitoring and control purposes because different traffic and applications should satisfy specific QoS requirements [1]. Every multimedia applications like audio, videoconferencing, and video-streaming have their own QoS requirements and sensitivity in terms of throughput, delay, jitter, and loss [2]. Due to this, QoS assessment and monitoring must be performed on a continuous basis to ensure that the given strict QoS requirements (e.g., Service Level Agreements (SLA)) are met during the service delivery [3]. Traffic QoS measurement and monitoring provide an essential aid for the network administrator/operator to manage and control network resources and improve the network efficiency [4]. In addition to the above, QoS measurement or assessment is essential for routing, network planning and dimensioning, dynamic bandwidth allocation, congestion control, traffic engineering, SLA monitoring, accounting, proactive management of the network, ...etc. [5]. Moreover, continuous QoS evaluation plays a vital role in guaranteeing QoS in IP networks due to the different services provided and the increased volume of real-time applications [6]. Network traffic QoS evaluation is considered an essential application of network management and measurement to predict the future tendency of network performance and resources availability [7]. These QoS algorithms can be embedded into network systems to assess traffic QoS, improve the network performance and utilize available resources [6]. Additionally, if the assessment algorithm is embedded in a network device, it

may be used as a self-adaptation process for optimizing the network behavior. Accordingly, proactive decisions can be made based on the results of the measurement process of QoS of certain applications or specific links. Several algorithms have been proposed in the literature for network traffic QoS assessment and measurement. This paper proposes a new technique to estimate the QoS attained by multimedia applications transmitted over a communication network. In this research, videoconferencing multimedia applications will be considered. Nonlinear techniques like neural network, fuzzy logic, and genetic algorithms ...etc., showed a great nonlinear mapping ability, flexible and effective way of learning in the field of estimation. Linear models cannot capture any nonlinear patterns in the signal or system under consideration. On the other hand, nonlinear models are not suitable to be employed for the prediction of linear signals or systems. Therefore, none of them is universal or appropriate for all circumstances; and generally none of them is superior to the other. The best solution is to combine them in one model. This is motivated by the followings [8]. First, practically it is often difficult to verify whether a time series is generated from a linear or nonlinear system or process; thus, combining linear and nonlinear models is the appropriate solution. Second, generally real-world time series are not pure linear or nonlinear; they often mix both patterns, none of them which can be sufficient for modeling such cases. Hence, combined structure in time series can solve this complexity. Third, it is almost universally agreed in literature that there is no single model that can be employed for all situations; and single model may not be able to capture different patterns equally well. Therefore, the chance to capture different patterns can be increased by combining both linear and nonlinear models in a single model. The proposed approach for QoS assessment and analysis is based on using both linear/nonlinear regression models.

## II. RELATED LITERATURE

Extensive research was performed on devising methodologies for assessing QoS of the delivered multimedia applications over best-effort networks. Although there is no standard for QoS measurement, different methods are used. Generally, QoS measurement methods may be categorized into two classes: objective versus subjective and passive versus active measurements. Subjective measurements are made by people (i.e., the end user) under precise and restricted conditions. In contrast, objective measurements are based on mathematical modeling and analysis [9], [10].

In subjective assessment, specialists (typically 15 to 30 members) assess (hear/watch) the assigned audio/video by rating quality according to their perception of a five-point scale (5 Excellent, 4 Good, 3 Fair, 2 Poor, 1 Bad) under controlled conditions as set out in the ITU standard. The average rating over all the subjects for a given audio/video is termed as Mean Opinion Score (MOS) [11]. ITU has recommended different scaling ways for subjective testing [10]. This approach has such disadvantages as: need for plenty of human resources and assessment time consumption which make it impractical [12].

Objective assessment techniques are based on mathematical models that are used to estimate the quality of the multimedia application (audio or video). Objective quality measurement is used to evaluate the effect of: source coding, compression, bit rate, delay, bandwidth, synchronization and many others on a perceptual audiovisual quality in multimedia services [13]. In addition, QoS can also be measured objectively using calculated values such as packet transfer delay, loss ratio, and service availability [14]. There are several objective quality algorithms such as Perceptual Speech Quality Measure (PSQM) and Perceptual Evaluation of Speech Quality (PESQ) which provide an objective MOS-equivalent score for a

voice call [15]. In [16], the ITU recommendation G.107 introduced the E-model as an objective method to assess the multimedia quality. The E-model approximates the perceived quality as a function of coding and network parameters (like delay, signal to noise ratio (SNR), ...etc.). The output of this model is a single scalar, called an “*R* factor” derived from the sum of delays and equipment impairment factors. *R* factor, then, can be mapped to an estimated MOS using the equations stated in the ITU G.107 [16]. The E-model performs well in static IP networks but cannot adapt to the dynamic IP ones [17]. Due to problems in subjective and objective measurement methods, the need for developing new models to assess QoS becomes imperative.

Active and passive measurements are also very useful for monitoring IP network. Both can be used for performance and debugging network problems. The difference between both methods denotes that active monitoring actively creates and injects network traffic and estimates network performance or QoS of the actual (existing) traffic based on results obtained from the injected traffic. In contrast, passive monitoring passively captures and monitors the existing network traffic [18]. The active measurement approach relies on small test packets (usually called probe packets) that are sent into the network to measure its performance or specific application QoS [19]. Ping and trace route tools [20] are categorized under this approach. The active method requires some kind of optimization to minimize the number and size of probe packet and get accurate results at the same time [21]. In literature, numerous measurement tools are based on such active methods as: the Internet Control Message Protocol (ICMP), Echo Reply/Request messages (ping) which is defined in RFC 729 [22], Surveyor [23], Active Measurement Project (AMP) [24], and Service Monitoring Management Information Base (SM MIB) [25].

Unlike active measurements, passive measurement methods do not require any traffic to be generated and sent to the network; instead, it monitors the actual network traffic by using the following protocols [26]: Simple Network Management Protocol (SNMP) [27], RMON [28], and NetFlow [29]. These protocols are embedded inside network devices which capture the traffic passing through them to monitor the network. Therefore, the packet's statistics and measurements can be collected from routers, switches or end-point hosts without adding any new traffic.

Due to their efficient learning and prediction capabilities, nonlinear techniques like neural network, fuzzy logic, and genetic algorithms have been widely used in network behavior estimation [30]. The changes in network traffics have the features of multi-scale, nonlinearity and time-varying. Self-learning methods have emerged and been applied in network control management. Particularly, artificial neural network (ANN) and fuzzy logic are learning methods with a strong predictive power. They have been used for the best approximation of network traffic performance and QoS changes due to nonlinearity and uncertainty of network traffic.

In literature, various methods have been devised based on ANNs for estimating and predicting of the QoS of audio and video over IP networks [31], [32]. In [33] and [34], authors use ANNs and GAs to estimate the quality of speech and video application transmitted over communication networks. Moreover, various studies have applied fuzzy logic for the analysis and estimation of network traffic [35]-[37]. These studies developed fuzzy logic approaches to evaluate the QoS of time-sensitive multimedia applications (i.e., audio and videoconferencing) using the QoS parameters. In [38], authors proposed a system combining fuzzy C-means and regression model to assess the QoS of VoIP traffic transmitted over a simulated network.

In this study, a nonlinear autoregressive with exogenous input model (NARX) is used to assess and quantify the QoS of multimedia applications whose requirements are considered in the light of ITU-Recommendations. These applications include videoconferencing which the paper is going to evaluate. The use of NARX system is justified by the need for a QoS assessment technique that can relate input parameters with the evaluated QoS in a simple manner and provide numerical assessment rather than quantifications based on complex and time-consuming approaches. In addition, NARX has the advantage of accepting dynamic inputs (i.e., QoS parameters (delay, jitter, and loss) and past QoS values) represented by time series sets.

### III. NONLINEAR AUTOREGRESSIVE WITH EXOGENOUS INPUTS MODEL (NARX)

NARX model is a dynamic network with feedback including several layers [39]. This model is based on the discrete linear autoregressive with exogenous inputs (ARX) model generally used in time-series modeling [40]. NARX is extensively employed in various research areas like temporal pattern recognition, signal processing, time series prediction and industrial processes [41]. The NARX is proposed in [42], [43]. NARX predicts a time-series, which can be single or multidimensional.

In a linear ARX model whose input and output are  $u(t)$  and  $y(t)$  respectively [44], the current output  $y(t)$  is obtained by a linear combination of the weighted sum of past output values and current and past input values (i.e., regressors)  $y(t-1) \dots y(t-n_a)$  and  $u(t), u(t-1) \dots u(t-n_b)$ , respectively:

$$y(t) + a_1y(t-1) + \dots + a_{n_a}y(t-n_a) = b_1u(t) + b_2u(t-1) + \dots + b_{n_b}u(t-n_b) \quad (1)$$

NARX model [45] extends the ARX equation into a nonlinear mapping function. The equation modelling the NARX network behavior for time series prediction is shown in (2):

$$y(t) = f(a_1y(t-1) + \dots + a_{n_a}y(t-n_a) + b_1u(t) + b_2u(t-1) + \dots + b_{n_b}u(t-n_b)) \quad (2)$$

In the above equation,  $u$  and  $y$  are external input and output of the system, respectively.  $n_a$  and  $n_b$  are the maximum lags of the input and output orders, respectively.  $f(\cdot)$  is a nonlinear function, which combines the linearity and nonlinearity estimators. The linearity estimator is as in (1); and the nonlinearity estimator is expressed as the sum of series of nonlinear elements, like tree partition networks, wavelet networks, sigmoid functions and neural network. NARX model is an extension of linear models to precisely simulate nonlinearity in system dynamics. NARX model is shown in Fig. 1. It can be seen that the inputs of NARX model consist of two types: the external and previous outputs of the network.

The NARX model computes the output  $y$  in two steps [45]:

1. Computing regressors from the current and past input values and past output data which are the delayed inputs and outputs like  $u(t-1)$  and  $y(t-3)$ . As can be seen from (2) and Fig. 1, all regressors are inputs to both the linear and the nonlinear blocks of the nonlinearity estimator.
2. The nonlinearity estimator block maps regressors to the model output using a combination of nonlinear and linear functions. There are several available nonlinearity estimators like tree-partition networks, wavelet networks, and multilayer neural networks.

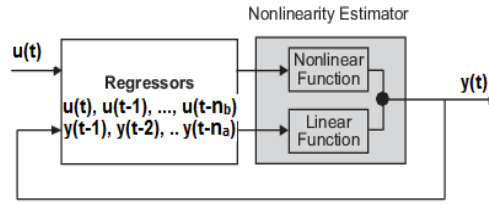

Fig. 1. Block diagram representation of NARX estimator

From the above discussion, model parameters are: inputs (exogenous), outputs (predicted), input delays order, and output delays order. Varying these parameters may produce a different model structure: with or without exogenous inputs, with or without delayed outputs (feedback), ...etc. The parameters of the NARX model are determined during the training phase of the model. These are obtained by minimizing the error between the model output (estimated or predicted) and the real response. This error is called loss function or cost function, which is a positive function of prediction errors  $e(t)$ . In general, this function is a weighted sum of squares of the errors. The loss function  $V(\theta)$  has the following general form, where parameter values are determined by minimizing  $V(\theta)$  with respect to  $\theta$  [46], [47]:

$$V(\theta) = \frac{1}{N} \sum_{t=1}^N e^T(t, \theta) W(\theta) e(t, \theta) \quad (3)$$

where  $N$  is the number of data samples;  $e(t, \theta)$  is an error vector at a given time  $t$ ; and  $W(\theta)$  is the weighting matrix.

After estimating the model and its parameters, several quality metrics may be used to assess and validate the quality of identified models. These include [48]-[50]:

1. Mean Squared Error measure (MSE),

$$MSE = \frac{1}{N} \sum_{t=1}^N e^T(t) e(t) \quad (4)$$

where  $e(t)$  is the signal whose norm is minimized for estimation; and  $N$  is the number of data samples in the estimation dataset.

2. Akaike's Final Prediction Error (FPE):

$$FPE = \det \left( \frac{1}{N} E^T E \right) \left( \frac{1 + \frac{n_p}{N}}{1 - \frac{n_p}{N}} \right) \quad (5)$$

where  $n_p$  is the number of free parameters in the model.  $n_p$  includes the number of estimated initial states;  $N$  is the number of samples in the estimation dataset;  $E$  is the  $N$ -by- $n_y$  matrix of prediction errors, where  $n_y$  is the number of output channels.

#### IV. NARX AS A QoS ASSESSMENT TECHNIQUE (METHODOLOGY)

In this paper, a QoS assessment framework using NARX is proposed. NARX is adapted to learn the nonlinear relationship between the measured QoS parameters and the assessed QoS. The proposed approach is used to measure the QoS of the multimedia applications transmitted over computer networks. NARX learns the relationship by means of a “supervised” manner, i.e., pairs of input and output values are provided in advance into the NARX structure. Input signals are taken and “fed forward” through the structure to the output. The proposed approach was developed in three phases: firstly, data collection and pre-processing; secondly,

NARX modeling; and finally, the analysis and validation of the proposed model performance in comparison with other prediction models.

As mentioned above, NARX is a nonlinear model which estimates output values based on the last outputs and some external data. In this study, NARX was used with three inputs represented by the measured QoS parameters (i.e., delay, jitter and losses) and another input represented by the previous values of the QoS. These inputs provide a single output data  $y(t)$ , corresponding to the value of the assessed QoS one step forward.

### ***A. Network Topology and Traffic***

In order to generate the inputs used to train and test the proposed NARX assessment system, different simulation scenarios were conducted using Network Simulator (NS) [51]. The network topology used for simulations was the same topology used in our previous study [35], [36] as shown in Fig. 2. This network had four pairs of source/destination hosts. The pair between N0 and N6 was used for multimedia transmissions. Cross-traffic, which is a non-video-conferencing traffic, (or sometimes called background traffic), is also used to intercede between multimedia traffic and make the network busy during some selected times. The cross traffic pairs were between N1 and N7, N2 and N8 and N3 and N9. In addition, the following simulation specifications were used: UDP was the transport protocol; link capacity between every two nodes was 2Mb/sec, queue size of 50 packets.

### ***B. Inputs and Outputs of the NARX Assessment System***

Using the above network, and after running the simulation, the QoS parameters were measured between the N0 and N6 (i.e., source and destination of videoconferencing application). The parameters' values were obtained from the generated trace file of the simulated network. Model inputs are the measured QoS parameters, which are delay, jitter and packet losses. These parameters are measured instantaneously, so they need to be preprocessed using a blocking technique that gathers every  $m$  consecutive packet in one block and calculates their average delay, jitter and loss values [35], [36]. The measured averaged QoS parameters time-series are ready to be used as external inputs of the NARX model. Another input for the NARX model is the previous values of the NARX output. These values were obtained from our previous study values to be used in train of the NARX model [35], [36]. These output values correspond to inputs QoS parameters. This means that every QoS value corresponds to specific QoS parameters values (i.e.,  $D_1$ ,  $J_1$  and  $L_1$  correspond to  $QoS_1$ ).

### ***C. NARX Training and Modeling***

The second phase of the assessment process is to train and build the NARX model. Based on the above steps, the data required for training and learning the NARX can be used to develop input-output linear and nonlinear models. The NARX was implemented by MATLAB 2008a [52]. The idea is to develop a model, whose estimated or predicted output best fits the experimentally recorded or measured output. Before estimates the parameters of the model, the collected data is divided into two sets. The first one is for the estimation of parameters; and the second one for the model validation.

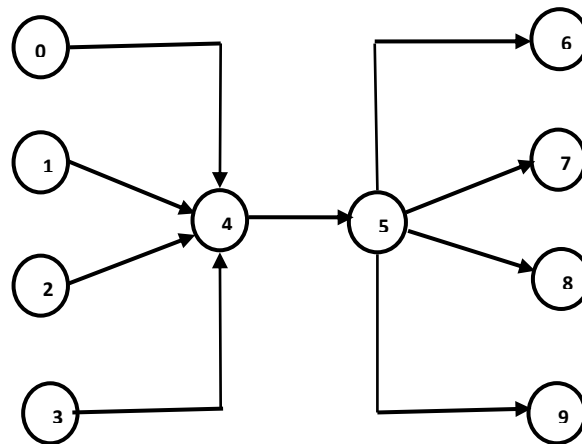

Fig. 2. The network topology

As shown in Fig. 3, the structure of the NARX model consisted of both a linear and a nonlinear function. In the calculation aspect of the NARX model, the output QoS of Videoconferencing was estimated by computing regressors from the current and past input values and past output data using both the linear and nonlinear function blocks of the nonlinearity estimator. Further, the estimator block mapped regressors to the model output using a combination of nonlinear and linear functions. The sigmoid transfer function was used as the nonlinear function in the estimator [53].

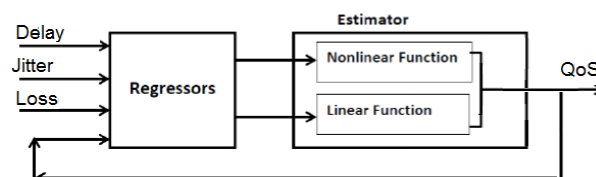

Fig. 3. NARX QoS estimation model

In this paper, the approach adopted to determine the model order is based on the evaluation of the quadratic criterion [46]. This is achieved by calculating the loss function obtained from minimizing the error between the model output (estimated or predicted) and the real output based on (3). Also, the orders of the models should be determined before the model validation process. For example,  $n_a$  and  $n_b$  in the NARX model should be determined before the model calibration. In our implementation, we determine a general range of orders before selecting the orders that predict the responses in highest accuracy by iterative search and minimize the error between the model output and the measured output. The minimization of prediction error cannot always lead to accurate models. So, after system models are calibrated, we further use a set of new simulation data to validate them. This is achieved using a fit-level function (%) to evaluate the accuracy of the calibrated models.

To summarize the process of constructing the NARX model to evaluate the QoS, Fig. 4 illustrates the estimation methodology. The available data traces (i.e., QoS parameters and the QoS) are divided into two sets: the training data set constitutes usually 50% of the available data, which is used to identify prediction model parameters; and the validation data set which is used to compare the estimated results with real data in order to evaluate the performance of the predictor.

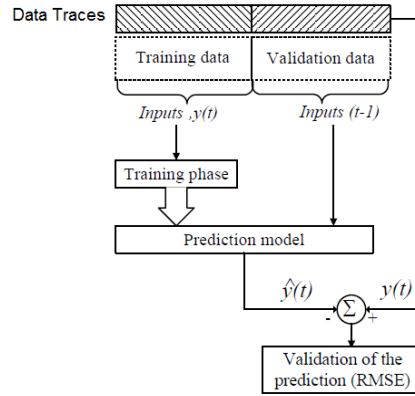

Fig. 4. QoS estimation methodology

There are three phases in QoS estimation methodology as shown in Fig. 4:

- The training phase: in this phase, model parameters are identified. Thus, a training data set is inserted into the training algorithm. This data set is composed of the inputs (QoS parameters) and outputs (QoS). The training algorithm estimates model parameters which provide the minimum error between model outputs  $\hat{QoS}$  and the real QoS values based on (3).
- The prediction phase: during this phase, only inputs (i.e., QoS parameters) from the validation data set are injected to the model in order to estimate  $\hat{QoS}$
- Validation of the prediction: in this phase, the accuracy of the prediction is evaluated based on calculating the MSE from (4).

## V. EXPERIMENTAL RESULTS AND DISCUSSIONS

Experiments have been conducted to evaluate the performance of the proposed NARX assessment system. Using the data acquired after running the simulation of the network shown in Fig. 2, a total of 500 samples were obtained. 250 samples were used for the training phase; and 250 for the validation phase. Several regression linear and nonlinear models were experimented to provide the best estimation of the QoS of the multimedia application transmitted over the computer network. Examples of these models are: linear ARX model and NARX with different nonlinearity estimator functions like Wavelet, Tree-partition and Sigmoid. In addition, model orders  $n_a$  and  $n_b$  were also computed and compared based on a loss or cost function (3). After the training data set had been fed to these models, model orders were estimated by minimizing the loss function as in (3). The optimum model orders obtained from the optimization of the loss function of different models were  $n_a=2$  and  $n_b=[2 \ 2 \ 2]$  for the NARX model with a loss function of 0.65. These optimized orders were obtained using the NARX with sigmoid nonlinear function, which presented the best results among other simulated models. Therefore, the results presented in this work were generated using the NARX sigmoid estimator with  $n_a=2$  and  $n_b=[2 \ 2 \ 2]$ .

The NARX model with the best estimate performance used the three input QoS variables with two lags per variable (delay ( $D(t)$  and  $D(t-1)$ ), jitter ( $J(t)$  and  $J(t-1)$ ) and a packet loss ratio ( $L(t)$  and  $L(t-1)$ ). In addition, based on  $n_a=2$ , the model used two past output values of QoS as inputs ( $QoS(t-1)$  and  $QoS(t-2)$ ). The developed nonlinear model was then simulated; and the obtained simulated results of QoS values were compared with real values by calculating their MSE values (5) and FPE values (6). Fig. 5 illustrates the QoS samples that were used to train the NARX model. Fig. 6, 7 and 8 show the actual and predicted (estimated) QoS using the



proposed NARX system. It can be observed that the NARX method forecasts QoS very closely to the actual QoS values in most of the time period.

To check the accuracy of the estimated QoS compared to the actual values, FPE and MSE criteria of the developed NARX model were computed with the same orders of  $n_a=2$  and  $n_b=[2 \ 2 \ 2]$ , but with different nonlinear functions. FPE provides a measure of the model quality by simulating the model tested with a different data set. According to Akaike's theory, the most accurate model has the smallest FPE. After calculating FPE for several developed models, a comparison among them was performed as illustrated in Table 1. We found that the minimum FPE was 0.80 for the developed model adopted in this paper, whereas other models had high FPE values. Moreover, MSE was also computed between the output of the NARX model and the actual QoS. MSE of our model was 0.068 compared to MSEs of other models. As for the FPE, the best model is the one which has the minimum MSE.

TABLE 1  
FPE AND MSE FOR DIFFERENT MODELS

Model	FPE	MSE
NLARX with Wavelet Nonlinear Function	48.3	48.1
NLARX with Linear Function Only	48	50.5
NLARX with Sigmoid Nonlinear Function with Ten Units	3.82	3
NLARX with Sigmoid Nonlinear Function with Two Units (used in this paper)	0.8	0.068

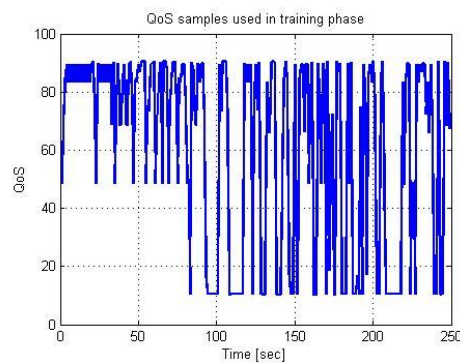

Fig. 5. Input QoS samples used in the training phase of the developed NARX model

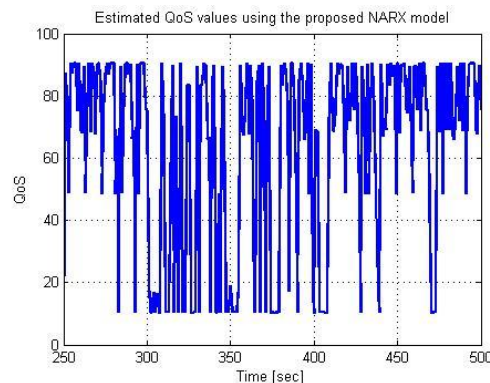

Fig. 6. Output of the proposed NARX model (i.e., estimated QoS)

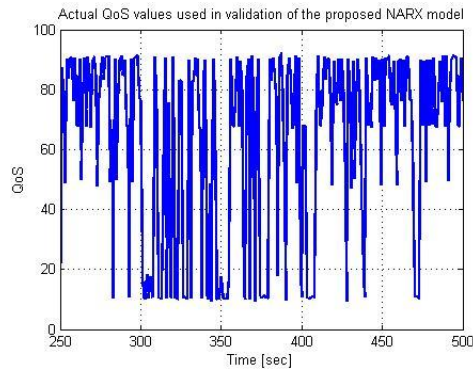

Fig. 7. Actual QoS samples used in the validation phase of the developed NARX model

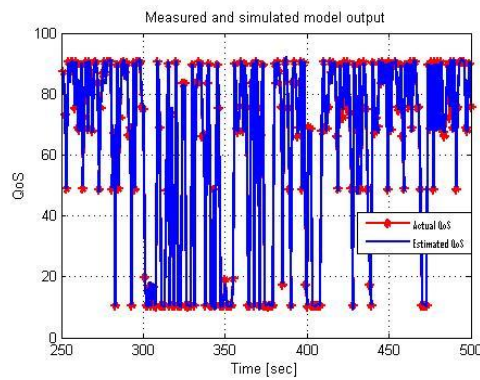

Fig. 8. Actual QoS versus estimated QoS

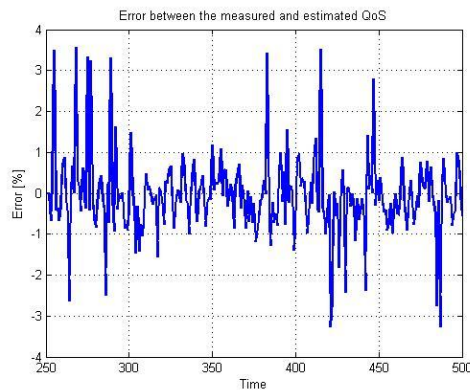

Fig. 9. Error between the actual QoS and estimated QoS

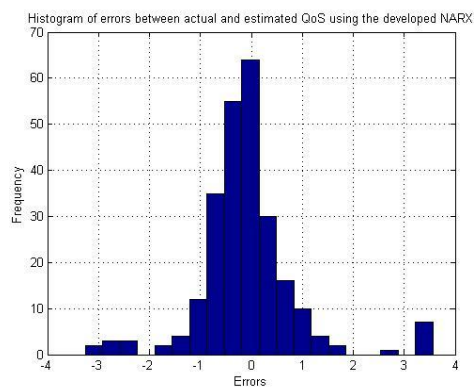

Fig. 10. The error histogram of errors between the actual QoS and estimated QoS

To observe the difference between the estimated and actual QoS, Fig. 9 depicts the prediction error between the actual output and estimated QoS. From this, it is very clear that the

discrepancy between the actual and the estimated QoS is very small. The maximum and minimum errors are: 3.56 and -3.27, respectively with mean and standard deviation of -0.097 and 0.96, respectively. Moreover, the histogram of these errors is shown in Fig. 10. It is very clear that more than 60% of the errors are zeros while other errors are mostly distributed between -1 and 1. This indicates that the developed NARX model produced outputs which mostly captured the actual ones.

Fig. 11 shows the autocorrelation of the output residuals of the estimated QoS (top) as well as the cross-correlation of the inputs of the developed NARX model and its output (i.e., estimated QoS) (bottom). In this figure, the horizontal axis represents the number of lags (i.e., time difference in samples) between the signals at which the correlation is estimated.

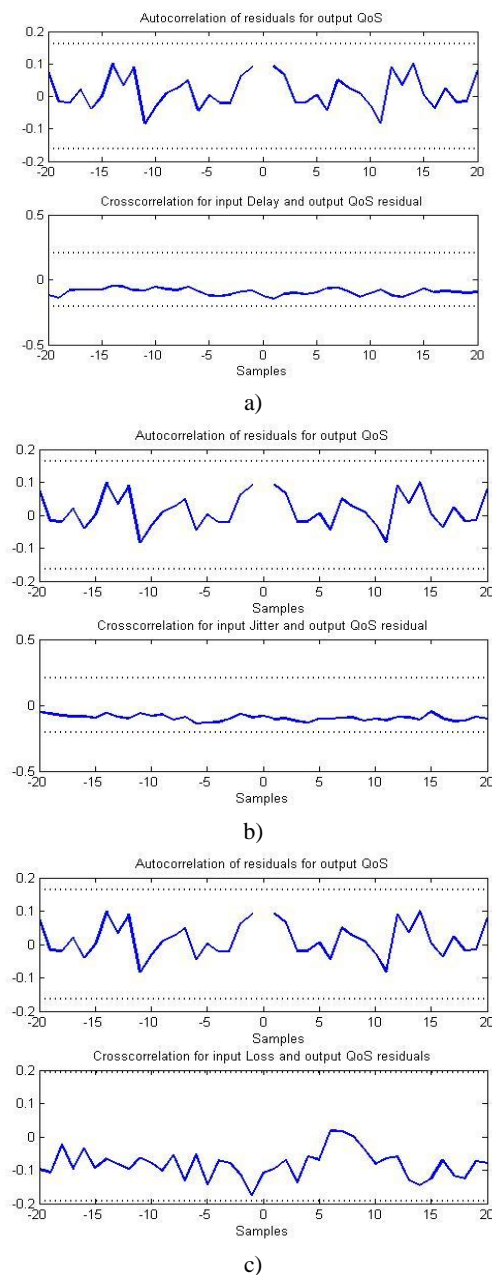

Fig. 11. a) Autocorrelation of residuals of the actual and estimated QoS and cross-correlation between the input delay and the estimated QoS. b) Autocorrelation of residuals of the actual and estimated QoS and cross-correlation between the input jitter and the estimated QoS. c) Autocorrelation of residuals of the actual and estimated QoS and cross-correlation between the input packet loss ratio and the estimated QoS

Also, the dashed lines on the plots represent the confidence interval of the corresponding estimates. A good estimation model must have residual autocorrelation and cross-correlation functions within the given confidence interval. This indicates that the residuals are uncorrelated (i.e., no relationship between them). From this figure, our NARX model produced residuals inside the confidence interval. This means that they are uncorrelated and classified as a good estimation model.

## VI. CONCLUSIONS

In this paper, an exploration of using a nonlinear autoregressive model was presented to evaluate QoS of multimedia traffic. An NARX model was considered to perform that. This technique showed how QoS parameters may be combined and used as inputs to the assessment system. In the devised model, the assessment process is an end-to-end process regardless to the cooperation of routers. The key conclusion for this work is that the developed model provided an effective measurement method of the application QoS, which can be used to infer the network performance of any network topology. From the obtained results, NARX model showed that it is a powerful estimation technique due to the high accuracy of the resulted QoS values compared to the actual values in terms of FPE and MSE criteria. In addition, the devised NARX QoS assessment system also presented wonderful results in terms of the autocorrelation of residuals of the actual and estimated QoS and cross-correlation between the input QoS parameters and the estimated QoS, where these correlations were inside the confidence interval. This indicates that the NARX model performed well in the assessment process. Nevertheless, NARX model has the drawback of selecting the best orders and nonlinear function to produce the most accurate result.

## REFERENCES

- [1] Q. Tan, Y. Liu, Y. Han, W. An, S. Ci, and H. Tang, "A wireless traffic QoS optimization algorithm based on fuzzy measurement," *Communications*, vol. 9, no. 10, pp. 729-736, 2014.
- [2] C. Wang and T. Lin, "Application of Neural Networks for Achieving 802.11 QoS in heterogeneous channels," *Computer networks*, vol. 52, no. 3, pp. 581-592, 2008.
- [3] B. Raouyane, M. Bellafkih, M. Errais, and M. Ramdani, "Monitoring IMS based eTOM-WSOA-BPEL," *International Review on Computers and Software*, vol. 5, no. 3, pp. 355-362, 2010.
- [4] Y. Zhang, H. Li, and S. Yan, "A network traffic prediction algorithm based on hybrid model," *Proceedings of International Conference on Education Technology and Computer*, vol. 43, pp. 1-5, 2012.
- [5] R. Clegg, "A practical guide to measuring the hurst parameter [J]," *International Journal of Simulation:Systems,Science & Technology*, vol. 7, no. 2, pp. 3-14, 2006.
- [6] M. Barabas, G. Boanea, A. Rus, V. Dobrota, and J. Domingo-Pascual, "Evaluation of network traffic prediction based on neural networks with multi-task learning and multiresolution decomposition," *Proceedings of the IEEE International Conference on Intelligent Computer Communication and Processing*, pp. 95-102, 2011.
- [7] X. Shuona and Z. Biqing, "Network traffic prediction model based on auto-regressive moving average," *Networks*, vol. 9, no. 3, pp. 653-659, 2014.
- [8] P. Zhang, "Time series forecasting using a hybrid ARIMA and neural network model," *Neurocomputing*, vol. 50, pp. 159-175, 2003.

- [9] K. Seshadrinathan, R. Sundararajan, A. Bovik, and L. Cormack, "Study of subjective and objective quality assessment of video," *IEEE Transactions on Image Processing*, vol. 19, no. 6, pp. 1427-1441, 2010.
- [10] ITU-T Recommendation P.910, "Subjective video quality assessment methods for multimedia applications," *International Telecommunication Union*, 1999.
- [11] S. Winkler and P. Mohandas, "The evolution of video quality measurements: from PSNR to hybrid metrics," *IEEE Transactions on Broad-Casting*, vol. 54, no. 3, pp. 660-668, 2008.
- [12] P. Kumar and S. Chandramathi, "Video quality assessment methods: a bird's-eye view," *Computer, Electrical, Automation, Control and Information Engineering*, vol. 8, no. 5, pp. 772-778, 2014.
- [13] ITU-T Recommendation SG9, "Broadband cable and TV," *International Telecommunication Union*, <http://www.itu.int/ITU-T/studygroups/com09>
- [14] N. Staelens, M. Pinson, P. Corriveau, F. Turck, and P. Demeester, "Measuring video quality in the network: from quality of service to user experience," *Proceedings of International Workshop on Video Processing and Consumer Electronics*, pp. 5-6, 2015.
- [15] S. Pennock, "Accuracy of the perceptual evaluation of speech quality (PESQ) algorithm," *Proceedings of Workshop Measurement of Speech and Audio Quality in Networks*, pp. 1-19, 2002.
- [16] ITU-T Recommendation G.107, "The e-model, a computational model for use in transmission planning ITU-t standard," *International Telecommunication Union*, 2003.
- [17] L. Sun, "Speech quality prediction for voice over internet protocol networks," *PhD Thesis*, University of Plymouth, 2004.
- [18] A. Oslebo, "Infrastructure for active and passive measurements at 10Gbps and beyond," *Produced by the UNINETT-led Working Group on Network Monitoring*, April 2015, [http://services.geant.net/cbp/Knowledge\\_Base/Network\\_Monitoring/Documents/CBP-5\\_infrastrucure-for-active-and-passive-measurements\\_final.pdf](http://services.geant.net/cbp/Knowledge_Base/Network_Monitoring/Documents/CBP-5_infrastrucure-for-active-and-passive-measurements_final.pdf).
- [19] A. Mamun, S. Anwar, and H. Ali, "Development of monitoring tools for measuring network performances: a passive approach," *Computer Science and Technology*, vol. 6, no. 4, pp. 81-85, 2015.
- [20] Understanding the Ping and Traceroute Commands, [http://www.cisco.com/image/gif/paws/12778/ping\\_traceroute.pdf](http://www.cisco.com/image/gif/paws/12778/ping_traceroute.pdf).
- [21] C. Anderton. *Passive vs. Active Monitoring*, 2001.
- [22] J. Postel, "Internet control message protocol. RFC 792," [online] Last accessed on 26<sup>th</sup> May 2012 at URL: <http://www.ietf.org/rfc/rfc0792.txt>
- [23] Surveyor Measurement Tool, [online] Last accessed on 6<sup>th</sup> May 2012 at URL: <http://www.advanced.org/surveyor/>
- [24] National Laboratory for Applied Network Research (NLANR), [online] Last accessed on 27<sup>th</sup> May 2012 at URL: <http://moat.nlanr.net/>
- [25] Y. Choi and I. Hwang, "In-service QoS monitoring of real-time applications using SM MIB," *Network Management*, vol. 15, no. 1, pp. 31-42, 2005.

- [26] T. Brekne, M. Clementsn, P. Heegaard, T. Ingvaldsen, and B. Viken, "State of the Art in performance monitoring and measurements," *Fornebu: Telenor Forskning og Utyikling. R&D Report R15/2002*, 2002.
- [27] J. Case, *Simple Network Management Protocol*, RFC 1157, 1990.
- [28] S. Waldbusser, R. Cole, C. Kalbfleisch, and D. Romascanu, "Introduction to the remote monitoring (RMON) family of MIB modules," August 2003. <https://tools.ietf.org/html/rfc3577>.
- [29] CISCO. *Introduction to Cisco IOS NetFlow - A Technical Overview*, 2012.
- [30] G. Pankaj and N. McKeown, "Algorithms for packet classification," *IEEE Network*, vol. 15, no. 2, pp. 24-32, 2001.
- [31] H. Ramesh, Gowrishankar, and P. Satyanarayana, "A QoS provisioning recurrent neural network based call admission control for beyond 3G networks," *IJCSI International Journal of Computer Science Issues*, vol. 7, no. 5, pp. 7-15, 2010.
- [32] J. Frnda, J. Rozhon, M. Voznak, J. Lin, and T. Wu, "A new tool for quality of multimedia estimation based on network behaviour," *Perspectives in Science*, vol. 7, pp. 87-94, 2016.
- [33] M. Mrvova and P. Pocta, "Quality estimation of synthesized speech transmitted over IP channel using genetic programming approach," *Proceedings of International Conference on Digital Technologies*, pp. 39-43, 2013.
- [34] A. Bhattacharya, A. Parlos, and A. Atiya, "Prediction od MPEG-coded video source traffic using recurrent neural networks," *IEEE Transactions on Signal Processing*, vol. 51, no. 8, pp. 2177-2190, 2003.
- [35] Y. Al-Sbou, R. Saatchi, S. Al-Khayatt, R. Strachan, M. Ayyash, and M. Saraireh, "A novel quality of service assessment of multimedia traffic over wireless ad hoc networks," *Proceedings of the Second IEEE International Conference on Next Generation Mobile Applications, Services, and Technologies*, pp. 479-484, 2008.
- [36] Y. Al-Sbou, "Fuzzy logic estimation system of quality of service for multimedia transmission," *International Journal of QoS Issues in Networking*, vol. 1, no. 1, pp. 1-9, 2010.
- [37] M. Saraireh, R. Saatchi, U. Shur, and R. Strachan, "Fuzzy logic based evaluation of quality of service for multimedia transmission," *Proceedings of PREP 2004*, 2004.
- [38] A. Dogman, R. Saatchi, and S. Al-Khayatt, "Quality of service using a combination of fuzzy c-means and regression model," *International Journal of Electronics and Electrical Engineering*, vol. 6, no. 1, pp. 62-69, 2012.
- [39] C. Schatzl, F. Schneider, P. Abatti, and J. Nievola, "Fuzzy-NNARX based tool for monitoring and predicting patients conditions using selected vital signs," *IJCSNS International Journal of Computer Science and Network Security*, vol. 15, no. 1, pp. 113-122, 2015.
- [40] S. Fahimifard, S. Mohaddes, H. Mohammadi, and R. Keshtkar, "Application of NNARX to agriculture sector value added forecasting: a case of Iran's agriculture sector," *African Journal of Agricultural Research*, vol. 7, no. 27, pp. 3918-3924, 2012.
- [41] E. Diaconescu, "The use of NARX neural networks to predict chaotic time series," *WSEAS Transactions on Computer Research*, vol. 3, no. 3, pp. 182-191, 2008.
- [42] T. Lin, B. Horne, P. Tino, and C. Giles, "Learning long-term dependencies in NARX recurrent neural networks," *IEEE Transactions on Neural Networks*, vol. 7, no. 6, pp. 1329-1338, 1996.

- [43] H. Siegelmann, B. Horne, and C. Giles, "Computational capabilities of recurrent NARX neural networks," *IEEE Transactions on Systems, Man, and Cybernetics*, vol. 27, no. 2, pp. 208-15, 1997.
- [44] L. Ljung, *System Identification*, Wiley Online Library, 1999.
- [45] Mathworks, Identifying Nonlinear ARX Model, 2014, <http://www.mathworks.com/help/>
- [46] L. Ljung, *System Identification Toolbox User's Guides*, The Math Works, Natick, 2000.
- [47] System Identification Toolbox, MathWorks, <https://www.mathworks.com/help/ident/ug/model-quality-metrics.html>.
- [48] T. Chai1 and R. Draxler, "Root mean square error (RMSE) or mean absolute error (MAE)? arguments against avoiding RMSE in the literature," *Geoscientific Model Development*, vol. 7, no. 3, pp. 1247-1250, 2014
- [49] S. Khorshidi and M. Karimi, "Modified AIC and FPE criteria for autoregressive (AR) model order selection by using LSFB estimation method," *Proceedings of IEEE International Conference on Advances in Computational Tools for Engineering Applications*, pp. 374-379, 2009.
- [50] System Identification Toolbox, MATLAB Release 2014, The MathWorks, Inc., <https://www.mathworks.com/help/ident/ug/model-quality-metrics.html>
- [51] K. Bauer and P. Sambhoos, *Network Simulator*, University of Colorado at Boulder, <http://www.isi.edu/nsnam/ns/>
- [52] MATLAB Toolbox Release 2016, The MathWorks, Inc., <https://www.mathworks.com/products/matlab/>, 2016.
- [53] L. Duch and N. Jankowski, "Survey of Neural Transfer Functions," *Neural Computing Surveys*, pp. 163-212, 1999.