

Discrimination between Transformer Inrush Current and Internal Fault using Combined DFT-ANN Approach

Eyad A. Feilat

Department of Electrical Engineering, The University of Jordan, Amman, Jordan
e-mail: e.feilat@ju.edu.jo

Received: January 14, 2015

Accepted: March 7, 2015

Abstract— This paper presents a digital protection technique based on combined Discrete Fourier Transform (DFT) and artificial neural network (ANN) for discrimination between the magnetizing-inrush and internal-fault currents in three-phase power transformers. A full-cycle DFT is firstly applied as a preprocessing module to extract distinctive features, namely the magnitudes of the fundamental and second harmonic frequency components I_1 and I_2 , respectively, from transient differential phase currents. The 3-phase current signals are sampled at a sampling rate of 20 samples per cycle. The features of phases a , b and c are then used to calculate the second harmonic ratio (SHR), I_2/I_1 . Secondly, the three SHRs are fed into an ANN for classifying the transient phenomenon into either magnetizing inrush or internal-fault current. The task of the ANN unit is to develop a block signal when the SHR exceeds a threshold value. As a result, a needless relay tripping when a transformer has an inrush current can be avoided. The ANN has the architecture of an input layer, hidden layer, and output layer. The input layer has three neurons representing the SHR of each differential phase current. The neurons of the hidden layer were selected based on speed and accuracy. The output layer has one neuron with an output 0 (no trip) for inrush current or 1 (trip) for internal fault. The ANN has been trained using Levenberg-Marquardt (LM) algorithm with log-sigmoid transfer functions in the hidden and output layers, respectively. Training and testing patterns of inrush and fault currents over a wide range of inception angles have been obtained by computer simulation of a 3-phase non-linear transformer bank using MATLAB/Simulink. Simulation results show that the proposed technique can be considered as an effective digital protection approach for fast and accurate discrimination between inrush and internal fault-currents of power transformers.

Keywords— ANN, DFT, inrush current, simulation, transformer protection.

I. INTRODUCTION

Power transformers suffer from the phenomenon of magnetizing inrush current during energization when their cores retain some residual flux. The effect of this inrush current could cause mal-operation of the protective relays. Since the magnetizing inrush current generally contains a large second harmonic component in comparison to a short-circuit current, conventional transformer protective schemes are designed to avoid false tripping due to inrush current. They as well block or restrain the relay operation by sensing the large second harmonic or by implementing delays in overcurrent or differential protection, or by using different approaches. However, the second method is undesirable because of the potential danger of delaying time during short-circuit conditions. Other techniques require lots of computing time [1]-[6].

There has been extensive research on applications of improved digital protective methods to power transformer protection over the last two decades. In particular, artificial neural networks have been developed for accurate and effective discrimination between inrush and internal-fault currents [7]-[11]. These ANNs employ feature extraction techniques based on either time or frequency domain signals, or both. As opposed to conventional techniques, ANN techniques have several advantages over conventional computing methods. These advantages include the ability to handle situations of incomplete and corrupted data, the ability to learn from examples, and the ability to generalize [12]. Based on these properties,

and several successful applications, ANN seems to be a faster and more reliable discriminating technique between transformer inrush and internal-fault currents.

In this paper, a digital protection approach of power transformers is presented. The proposed technique is used to discriminate a magnetizing inrush current from an internal-fault current by combining DFT and ANN. A sliding DFT is firstly applied as a pre-processing module to extract distinctive features for each phase of the 3-phase transient differential currents detected by the digital differential relays. These features represent the instantaneous magnitudes of I1 and I2 of phases a, b and c extracted by applying a full-cycle sliding DFT to differential currents. Secondly, the SHR of each phase is fed into an ANN for classifying the transient phenomenon into either magnetizing inrush or internal-fault current. The ANN is trained using LM algorithm with log-sigmoid transfer functions in hidden and output layers. Training and testing patterns of inrush and fault currents can be obtained by computer simulation of the transformer equivalent circuit during inrush and fault conditions and over a wide range of inception angles or from on-line measurements. The output layer has one neuron with an output 0 for inrush current or 1 for internal-fault current, respectively.

II. ARTIFICIAL NEURAL NETWORK

Multilayer feed-forward ANN is architecture of highly interconnected simple nonlinear processing elements (neurons) connected in parallel to perform useful computational tasks such as pattern recognition or classification as an alternative to conventional computing approaches. ANN computing characteristics are distinguished from conventional pattern recognition by their capability to map complex and highly nonlinear input-output patterns. ANN can be used to classify patterns by selecting the output, which best represents unknown input patterns in cases, where an exact input-output relationship is not easily defined. It has been proven that a network with one hidden layer can perform any nonlinear mapping and that no more than two hidden layers are needed for most applications [12]. ANN has attracted attention in the last decades to solve problems related to electric power system engineering such as load forecasting, security assessment, economic dispatch, and fault detection and classification [13]. In its basic form, an ANN consists of an input layer, one or more hidden layers and an output layer. Each layer consists of a set of neurons or nodes that are fully connected to the neurons in the next layer. The connections have multiplying weights associated with them. The node receives its input from either other nodes or from the outside world. The sum of all weighted inputs represents the node activation function. The output of the node is determined by an output function which responds to this activation. The number of neurons and hidden layers is problem-based. The process of determining the weights is called training process. In the training process, sets of input-output patterns are associated by properly adjusting weights in the network, so that a sum of squared error function can be minimized:

$$E = \frac{\sum E_p}{N} = \frac{1}{2N} \sum_p \sum_k (t_k^{(p)} - O_k^{(p)})^2 \quad (1)$$

where E_p is the pattern error, t_k is the target (desired) output, and O_k is the actual output of the neural network. Various training algorithms have been developed to adapt the weights in ANNs to reduce the error E_p . The most popular learning method for training ANNs is the back-propagation (BP) algorithm. This algorithm employs an iterative gradient descent rule to

adapt weights; and the error is calculated and propagated backwards from the output to the hidden and input layers [12].

Although the BP algorithm is effective, it suffers from very poor convergence rate. Therefore, several approaches including Newton's method, conjugate gradients, or the LM optimization technique have been developed. Among the above mentioned methods, the LM algorithm is widely accepted as the most efficient training algorithm in the sense of realization accuracy. It gives a good compromise between the speed of Newton's algorithm and the stability of the steepest descent method. Consequently, it constitutes a good transition between these methods [14]. In this study, the proposed ANN has been trained using the LM learning algorithm.

III. CALCULATION OF THE SECOND HARMONIC RATIO

Discrimination between an inrush and an internal-fault condition is often based on inrush detection algorithm to avoid the needless trip by magnetizing inrush current. The discrimination algorithm is based on the fact that a second-harmonic current component is present within the differential current when transformer core becomes saturated. Conventional method of inrush current detection for transformer protection is based on comparing the second-harmonic and fundamental components. The ratio $|I_2/I_1|$ is so-called the SHR. If the SHR is greater than a set value, an inrush current condition is assumed and tripping is prevented. Otherwise, an internal fault condition is assumed and a tripping signal is issued to disconnect the transformer. The magnitudes of I_1 and I_2 can be digitally extracted using the Fourier approach. In this paper, a sampling rate of 20 samples per cycle (1000 Hz) with one-cycle window length is chosen. The relay stores a full-cycle of current samples and feeds them to a full-cycle DFT to extract the magnitudes of I_1 and I_2 current components.

Assume that the current waveform is sampled N times per period of the fundamental, and let the samples be denoted by $i_k=i(k\Delta t)$, the real and imaginary parts of the n^{th} harmonic (a_n and b_n) can be found. In terms of current samples starting at the r^{th} sample, $a_n^{(r)}$, $b_n^{(r)}$ and $|I_n^{(r)}|$ of the n^{th} harmonic can thus be calculated:

$$a_n^{(r)} = \frac{2}{N} \sum_{k=r}^{r+N+1} i_k \cos n \left(\frac{2\pi k}{N} \right), \quad n = 1, 2 \quad (2)$$

$$b_n^{(r)} = \frac{2}{N} \sum_{k=r}^{r+N+1} i_k \sin n \left(\frac{2\pi k}{N} \right), \quad n = 1, 2 \quad (3)$$

$$|I_n^{(r)}| = \sqrt{(a_n^{(r)})^2 + (b_n^{(r)})^2} \quad (4)$$

The result can be updated iteratively as each new sample becomes available. This is done by dropping the earliest sample and adding the new sample:

$$a_n^{(r+1)} = a_n^{(r)} + \frac{2}{N} [i_{N+r} - i_r] \cos n \left(\frac{2\pi r}{N} \right) \quad (5)$$

$$b_n^{(r+1)} = b_n^{(r)} + \frac{2}{N} [i_{N+r} - i_r] \sin n \left(\frac{2\pi r}{N} \right) \quad (6)$$

where i_r and i_{N+r} are the oldest and newest samples, respectively. Having determined I_1 and I_2 magnitudes, the transformer discrimination protection is then implemented [15]. When a new input sample arrives, the oldest sample is discarded. The SHR of each phase is calculated and fed to the ANN to identify the transient current as the inrush or internal fault based on the value of the SHR.

IV. NEURAL NETWORK TRAINING

The proposed ANN consists of three layers as shown in Fig. 1. The input layer has 3 neurons. The number of neurons of the hidden layer was selected based on a compromise between the speed and accuracy of the ANN during training and testing phases.

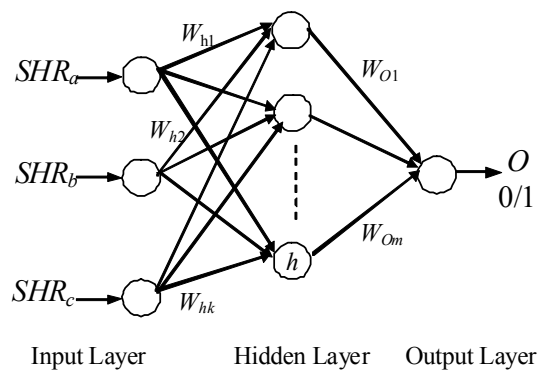

Fig. 1. Multilayer feed forward ANN

An attempt was made to minimize the number of hidden neurons. The mean squared error (MSE) was used as a performance criterion in this work. The output layer has one neuron, which gives a binary output of 0 or 1.

To train the proposed ANN, a large number of input-output patterns has been generated. Input patterns represent the instantaneous 3-phase SHRs of phases a , b and c detected by the differential relays of the transformer. Associated output patterns are either 0 corresponding to an inrush current during inrush transient or 1 corresponding to an internal fault current. In this paper, a total of 1500 simulations of inrush and internal-fault currents have been generated by computer simulation of a 3-phase nonlinear transformer bank over a wide range of inception angles α (0° - 180°), as shown in Fig. 2.

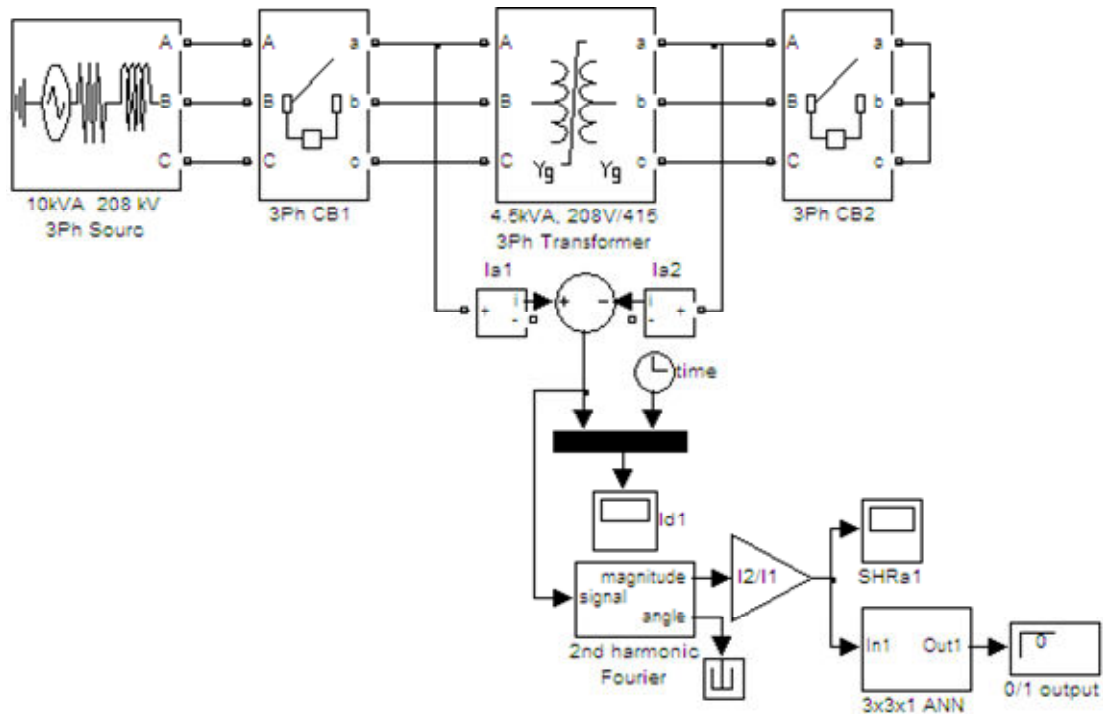
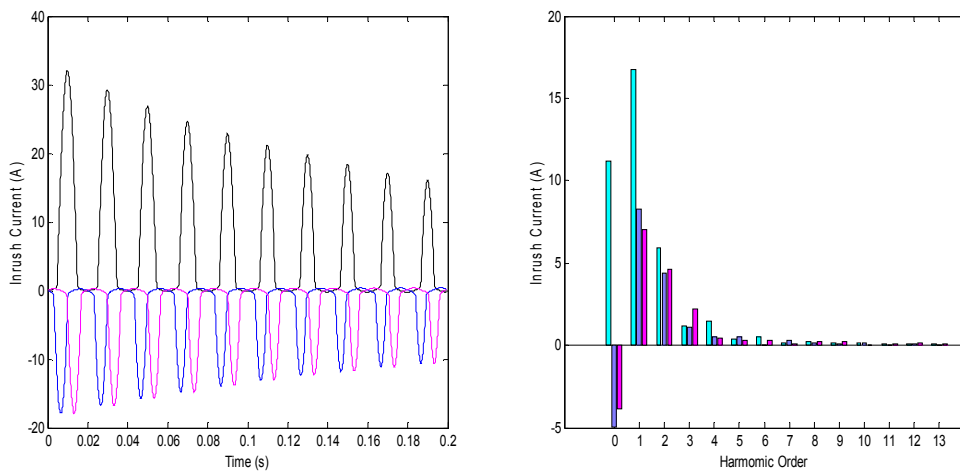

Fig. 2. MATLAB/Simulink schematic of a 3-phase nonlinear transformer

To simulate inrush currents, the circuit breaker is kept open-circuited, whereas to simulate internal faults, the circuit breaker is kept closed. The name plate of the 3-phase transformer bank is given in the Appendix.

Examples of 10 cycles of simulated inrush and internal-fault current signals, corresponding to $\alpha=0^\circ$ and $\alpha=90^\circ$, along with their harmonic spectrum are shown in Fig. 3.



a) Training 3-phase inrush currents and their harmonic spectrums at $\alpha=0^\circ$

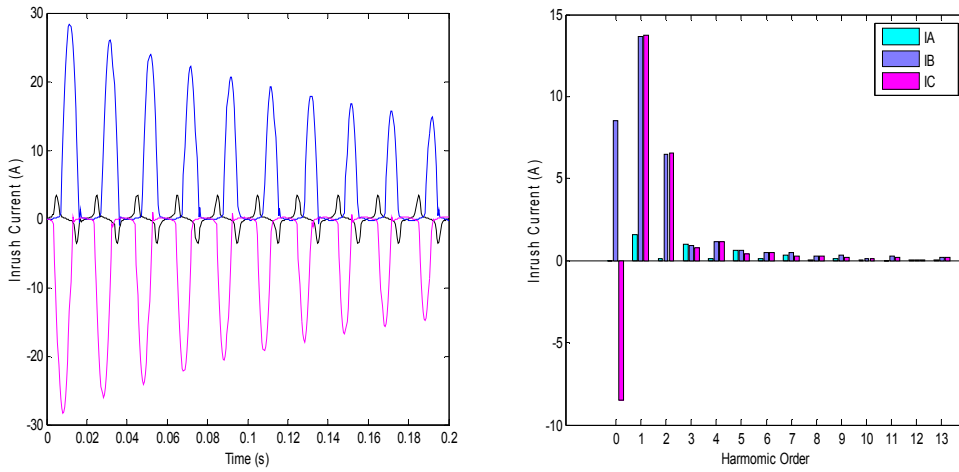

b) Training 3-phase inrush currents and their harmonic spectrums at $\alpha=90^\circ$

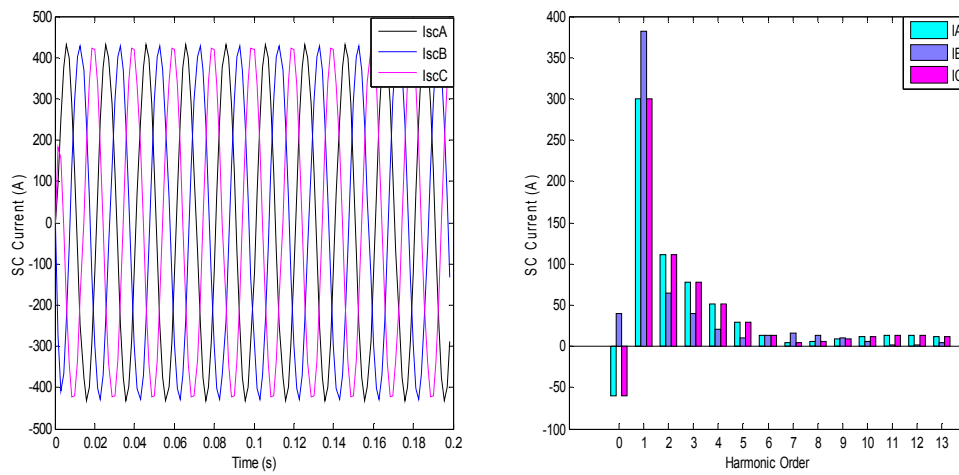

c) Training 3-phase-fault currents and their harmonic spectrums at $\alpha=0^\circ$

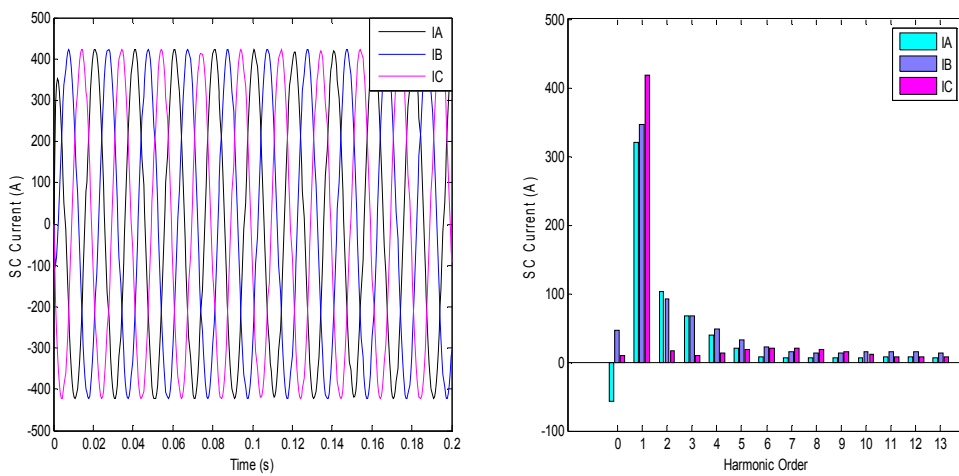

d) Training 3-phase-fault currents and their harmonic spectrums at $\alpha=90^\circ$

Fig. 3. Samples of 3-phase inrush and internal-fault currents

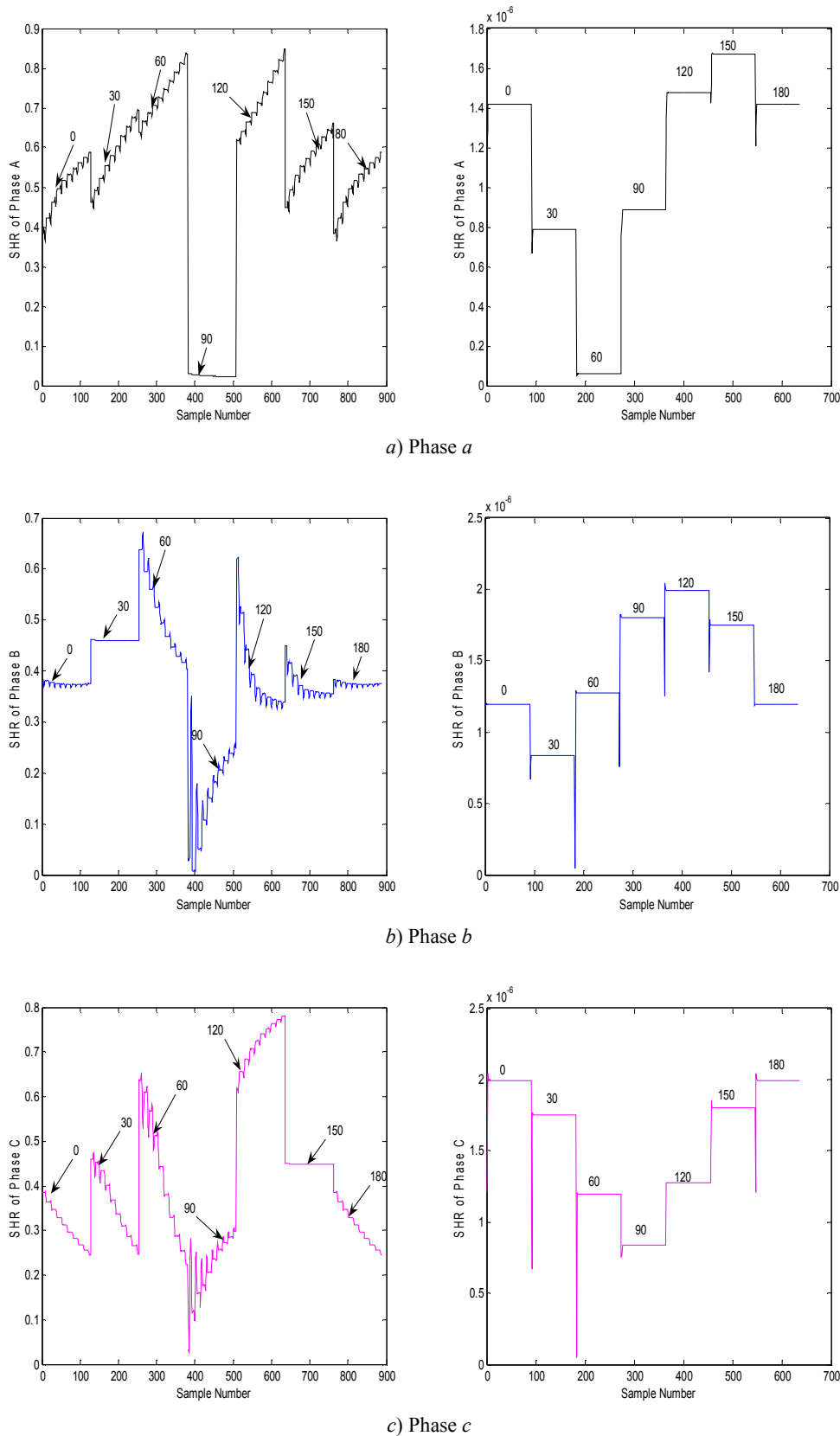

Fig. 4. Training input patterns of SHRs of 3-phase inrush and fault currents

These signals are used to extract SHR of the three phases (SHR_a , SHR_b and SHR_c) over a 10-cycle transient current at 0° , 30° , 60° , 90° , 120° , 150° and 180° inception angles, as depicted in

Fig. 4. As can be seen in Fig. 4, the SHR for the inrush transient varies with time and is much higher than that of the internal fault. Therefore, the two cases are separable and can be easily classified by the ANN.

Once the training matrices of the input-output patterns are obtained, the LM algorithm is applied to train the ANN. The “trainlm” of the MATLAB Neural Network Toolbox has been used with “log-sigmoid” functions for the hidden and output layers [14].

V. SIMULATION RESULTS

In this study, several tests have been performed to determine the optimum number of neurons in the hidden layer based on accuracy and speed. It was found that an ANN of 3 neurons in the hidden layer is a good choice. It leads to an $MSE < 1e^{-6}$ in 11 epochs, as shown in Fig. 5. Therefore, this architecture ($3 \times 3 \times 1$) has been adopted in this paper.

The training performance of the proposed ANN is depicted in Fig. 6. As can be seen from the plots, the ANN output perfectly fits the target values (0 for inrush current and 1 for internal-fault). It is evident that the ANN is able to classify the transients of the three phase currents to either inrush or internal-fault.

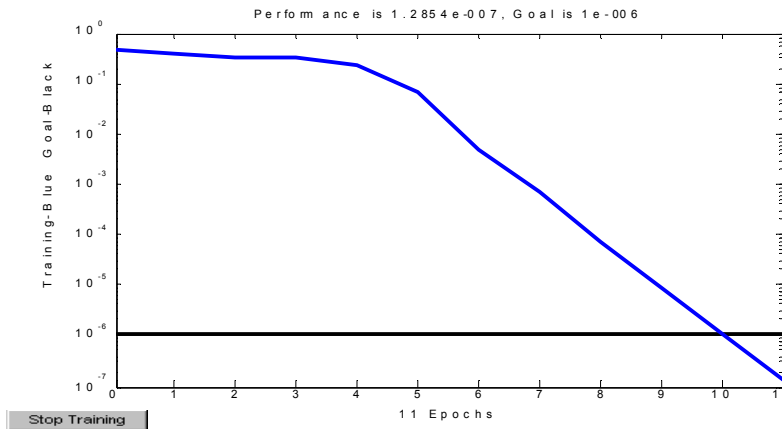
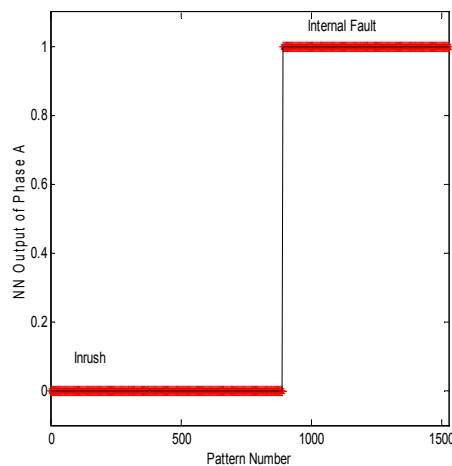
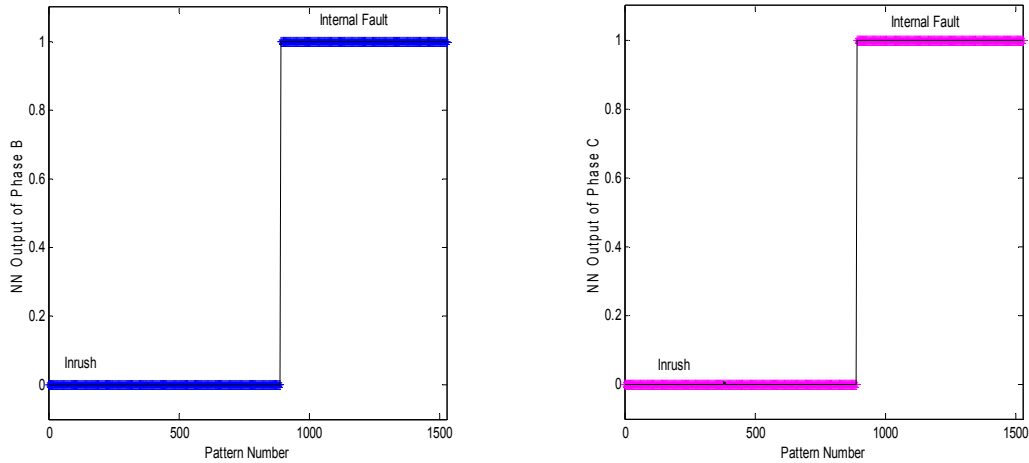

Fig. 5. MSE training convergence of the proposed ($3 \times 3 \times 1$) ANN



a) Training actual and target output patterns of phase *a*



b) Training actual and target output patterns of phase *b* c) Training actual and target output patterns of phase *c*

Fig. 6. Discrimination training performance of the proposed ANN

The proposed ANN operates in a static manner. The ANN is trained off-line. Once the desired performance is achieved, the weights of the ANN are frozen. Upon completion of the training phase, the generalization capability of the proposed ANN, when exposed to test patterns that are different from the training patterns, is tested. The testing performance of the ANN has been examined using 1100 input-output testing patterns representing inrush and internal-fault transients at inception angles (15° , 45° , 75° , 105° , 135° and 165°) as shown in Fig. 7. The results of the testing performance are shown in Fig. 8.

The testing phase simulations illustrate the efficiency of the proposed ANN. It can be seen that almost 100% of the 1100 tested inrush and fault patterns have been successfully classified. This resulted in the correct “no trip/trip” output signal.

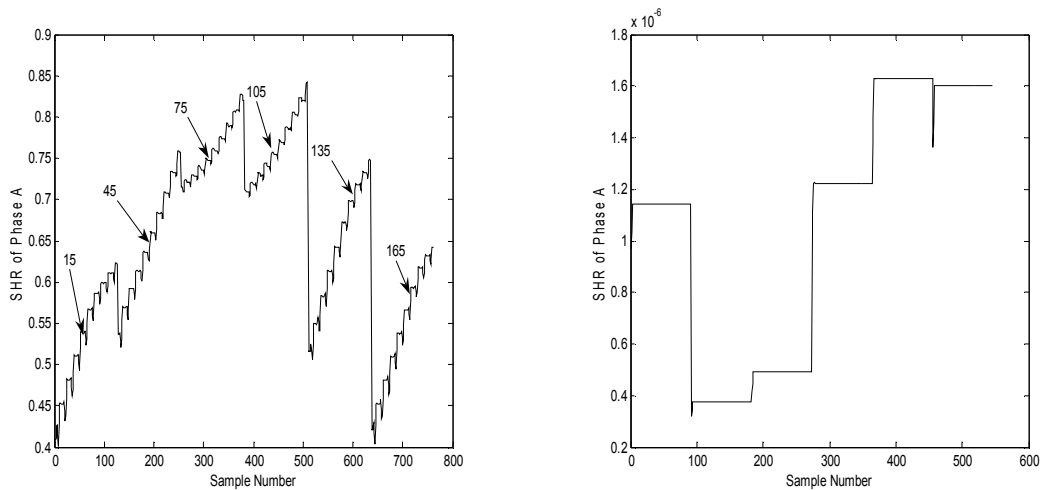

a) Phase *a*

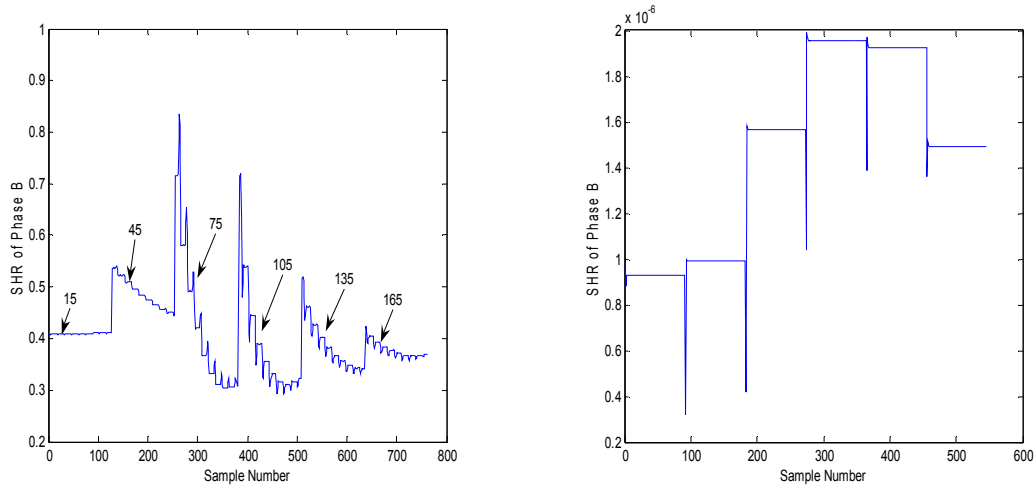

b) Phase b

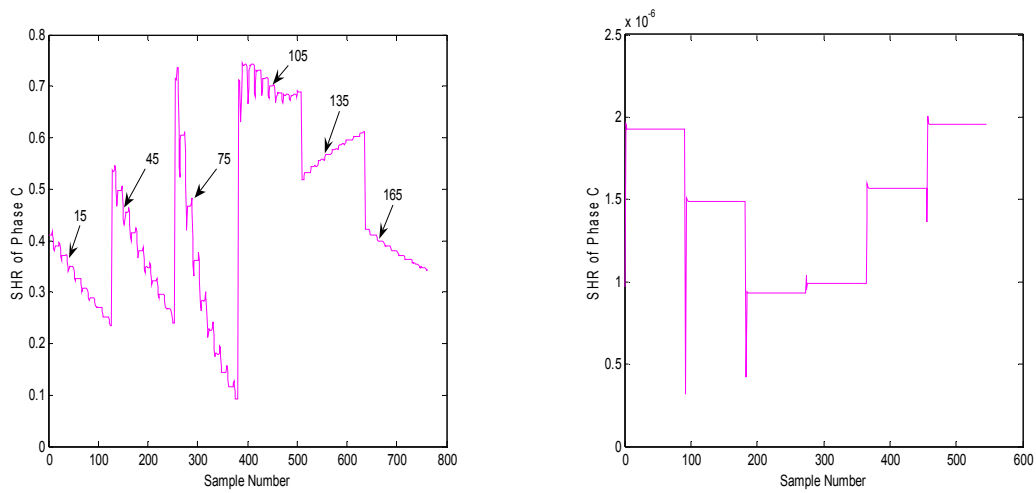

c) Phase c

Fig. 7. Testing input patterns of SHRs of 3-phase inrush and fault currents

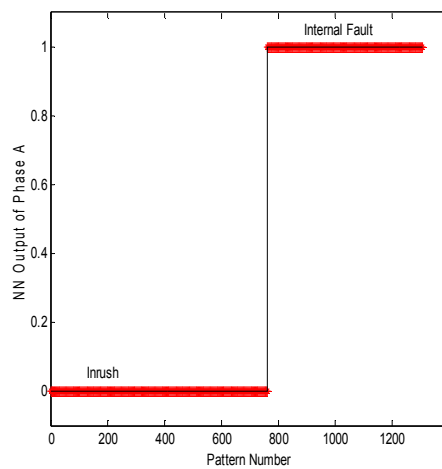

a) Testing actual and target output patterns of phase a

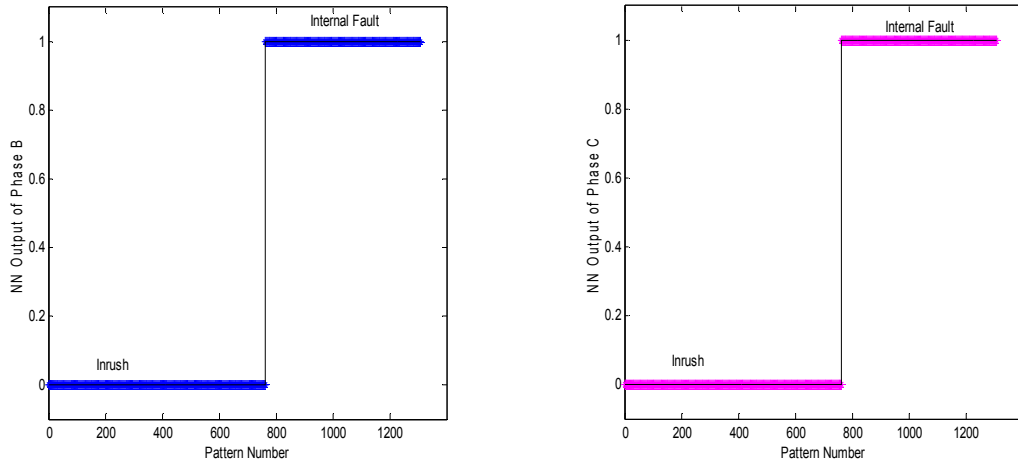

b) Testing actual and target output patterns of phase *b* c) Testing actual and target output patterns of phase *c*

Fig. 8. Discrimination testing performance of the proposed ANN

VI. CONCLUSION

In this paper, an ANN for inrush and internal-fault currents discrimination based on the SHR has been developed. The ANN has been trained using LM algorithm to generate a “no trip” (0) or “trip” (1) output signal according to the values of the SHR that are extracted from the transient differential current detected by the differential relay. The SHR has been calculated using sliding full-cycle DFT. Computer simulations of inrush and internal-fault transients of a 3-phase nonlinear transformer bank, over a wide range of switching angles, show that the performance of the proposed ANN-based discriminator is reliable and very encouraging. Simulation results show that the proposed ANN is able to classify current transients that have not been exposed to during the training phase. The proposed ANN-discriminator can be implemented by using dedicated digital differential relay; and it can be used to support or replace the conventional transformer differential relays.

APPENDIX

The parameters of the studied 3-phase 208/415-V, 50-Hz, 4.5-kVA nonlinear distribution transformer bank are as follows:

$$r_1=0.25\Omega, r'_2=0.134\Omega, x_{l1}=x'_{l2}=0.056\Omega, x_m=708.8\Omega.$$

All parameters given above are referred to the 120-V primary winding. The nonlinear characteristic of the transformer is shown in Fig. A.

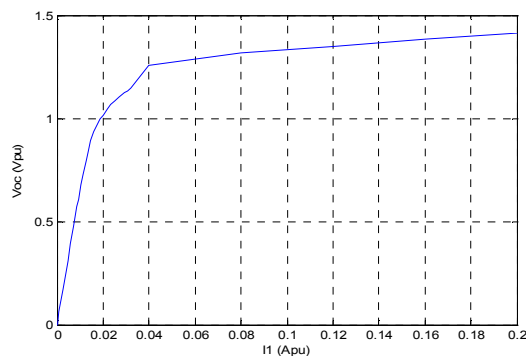

Fig. A. Magnetization curve of the nonlinear transformer

REFERENCES

- [1] M. A. Rahman and B. Jeyasurya, "A state-of-the-art review of transformer protection," *IEEE Trans. Power Delivery*, vol. 3, no. 2, pp. 534-544, 1988.
- [2] J. A. Skyes and I. F. Morrison, "A proposed method of harmonic restraint differential protection of transformers by digital computer," *IEEE Trans. Power Apparatus and systems*, vol. 91, pp. 1266-1272, 1997.
- [3] T. S. Sidhu and M. S. Sachdev, "On-line identification of magnetizing inrush and internal faults in three-phase transformers," *IEEE Trans. Power Delivery*, vol. 7, no. 4, pp. 1885-1891, 1992.
- [4] A. K. Al-Othman and K. M. El-Naggar, "A New digital dynamic algorithm for detection of magnetizing inrush current in transformers," *Electric Power Components and Systems*, vol. 37, no.4, pp. 355-372, April 2009.
- [5] R. Sedighi and M. R. Haghifam, "Detection of inrush current in distribution transformer using wavelet transform," *Electric Power Energy Systems*, vol. 27, pp. 361-370, 2005.
- [6] K. N. Al-Tallaq, A. Dahab, and M. Abo Zahhad, "Impedance-based algorithm for the discrimination between inrush and short-circuit current in single-phase transformers," *Electric Power Components and Systems*, vol. 31, no.6, pp. 593-604, June 2003.
- [7] L. G. Perez, J. Fleching, J. L. Meador, and Z. Obradovic, "Training an artificial neural network to discriminate between magnetizing inrush and internal faults," *IEEE Trans. Power Delivery*, vol. 9, no. 1, pp. 434-441, 1994.
- [8] P. Bastard, M. Meunier, and H. Regal, "Neural-network-based algorithm for power transformer differential relays," *IEE Proc. Generation, Transmission and Distribution*, vol. 142, no. 4, pp. 386-392, 1995.
- [9] P. L. Mao and R. J. Aggarwal, "A novel approach to the classification of the transient phenomena in power transformers using combined wavelet transform and neural network," *IEEE Trans. Power Delivery*, vol. 16, no. 4, pp. 654-660, 2001.
- [10] J. Piher, B. Grcar, and D. Dolinar, "Improved operation of power transformer protection using artificial neural network," *IEEE Trans. Power Delivery*, vol. 12, no. 3, pp. 1128-1136, 1997.
- [11] Z. Moravej, D. N. Vishwakarma, and S. P. Singh, "ANN-based protection scheme for power transformer," *Electric Machines and Power Systems*, vol. 28, pp. 875-884, 2000.
- [12] S. Haykin, *Neural Networks: a Comprehensive Foundation*, 2nd ed., Prentice Hall, NJ, 1999.
- [13] M. El-Sharkawi and D. Niebur, *Artificial Neural Networks with Applications to Power Systems*, IEEE Service Center, NJ, 1988.
- [14] H. Demuth and M. Beale, *Neural Network Toolbox User's Guide for Use with MATLAB*, The MathWorks. 2002.
- [15] A.T. Johns and S. K. Salman, *Digital Protection for Power Systems*, Peter Peregrines, 1995.